

# Portable Manual

Duplex unit

**Duplex Unit-A1**

**Canon**



## Application

This manual has been issued by Canon Inc. for qualified persons to learn technical theory, installation, maintenance, and repair of products. This manual covers all localities where the products are sold. For this reason, there may be information in this manual that does not apply to your locality.

## Corrections

This manual may contain technical inaccuracies or typographical errors due to improvements or changes in products. When changes occur in applicable products or in the contents of this manual, Canon will release technical information as the need arises. In the event of major changes in the contents of this manual over a long or short period, Canon will issue a new edition of this manual.

The following paragraph does not apply to any countries where such provisions are inconsistent with local law.

## Trademarks

The product names and company names used in this manual are the registered trademarks of the individual companies.

## Copyright

This manual is copyrighted with all rights reserved. Under the copyright laws, this manual may not be copied, reproduced or translated into another language, in whole or in part, without the written consent of Canon Inc.

***COPYRIGHT © 2001 CANON INC.***

*Printed in Japan*

## Caution









Use of this manual should be strictly supervised to avoid disclosure of confidential information.

---

# Symbols Used



---

This documentation uses the following symbols to indicate special information:

Symbol	Description
	Indicates an item of a non-specific nature, possibly classified as Note, Caution, or Warning.
	Indicates an item requiring care to avoid electric shocks.
	Indicates an item requiring care to avoid combustion (fire).
	Indicates an item prohibiting disassembly to avoid electric shocks or problems.
	Indicates an item requiring disconnection of the power plug from the electric outlet.
 Memo	Indicates an item intended to provide notes assisting the understanding of the topic in question.
 REF.	Indicates an item of reference assisting the understanding of the topic in question.
	Provides a description of a service mode.
	Provides a description of the nature of an error indication.

The following rules apply throughout this Service Manual:

1. Each chapter contains sections explaining the purpose of specific functions and the relationship between electrical and mechanical systems with reference to the timing of operation.

In the diagrams,  represents the path of mechanical drive; where a signal name accompanies the symbol, the arrow  indicates the direction of the electric signal.

The expression "turn on the power" means flipping on the power switch, closing the front door, and closing the delivery unit door, which results in supplying the machine with power.

2. In the digital circuits, '1' is used to indicate that the voltage level of a given signal is "High", while '0' is used to indicate "Low". (The voltage value, however, differs from circuit to circuit.) In addition, the asterisk (\*) as in "DRMD\*" indicates that the DRMD signal goes on when '0'.

In practically all cases, the internal mechanisms of a microprocessor cannot be checked in the field. Therefore, the operations of the microprocessors used in the machines are not discussed: they are explained in terms of from sensors to the input of the DC controller PCB and from the output of the DC controller PCB to the loads.

The descriptions in this Service Manual are subject to change without notice for product improvement or other purposes, and major changes will be communicated in the form of Service Information bulletins.

All service persons are expected to have a good understanding of the contents of this Service Manual and all relevant Service Information bulletins and be able to identify and isolate faults in the machine."



# Contents

## Chapter 1 Maintenance and Inspection

1.1 Periodically Replaced Parts .....	1
1.1.1 Periodically Replaced Parts .....	1
1.2 Durables .....	1
1.2.1 Durables .....	1
1.3 Periodical Servicing .....	1
1.3.1 Periodical Servicing Items .....	1

## Chapter 2 Error Code

2.1 Service Error Code .....	3
2.1.1 Error Code list .....	3

## Chapter 3 Outline of Components

3.1 Outline of Electrical Components .....	5
3.1.1 Outline of Electrical Components .....	5

## Chapter 4 System Construction

4.1 Basic Construction .....	7
4.1.1 Outline .....	7
4.2 Product Specifications .....	7
4.2.1 Specifications .....	7





---

---

# Chapter 1 Maintenance and Inspection

---

## 1.1 Periodically Replaced Parts

---

### 1.1.1 Periodically Replaced Parts

This machine has no periodically replaced parts.

## 1.2 Durables

---

### 1.2.1 Durables

This machine has no durables.

## 1.3 Periodical Servicing

---

### 1.3.1 Periodical Servicing Items

This machine has no periodical servicing items.



---

# Chapter 2 Error Code

---

## 2.1 Service Error Code

---

### 2.1.1 Error Code list

T-2-1

Code	Details code	Explanation	Countermeasure
E052	0000	Cause of faulty connection to duplex unit: Broken line or faulty duplex controller PCB or DC controller PCB	<ul style="list-style-type: none"><li>- Check the connectors of the duplex controller PCB and DC controller PCB.</li><li>- Replace the duplex controller PCB.</li><li>- Replace the DC controller PCB.</li></ul>



# Chapter 3 Outline of Components

## 3.1 Outline of Electrical Components

### 3.1.1 Outline of Electrical Components

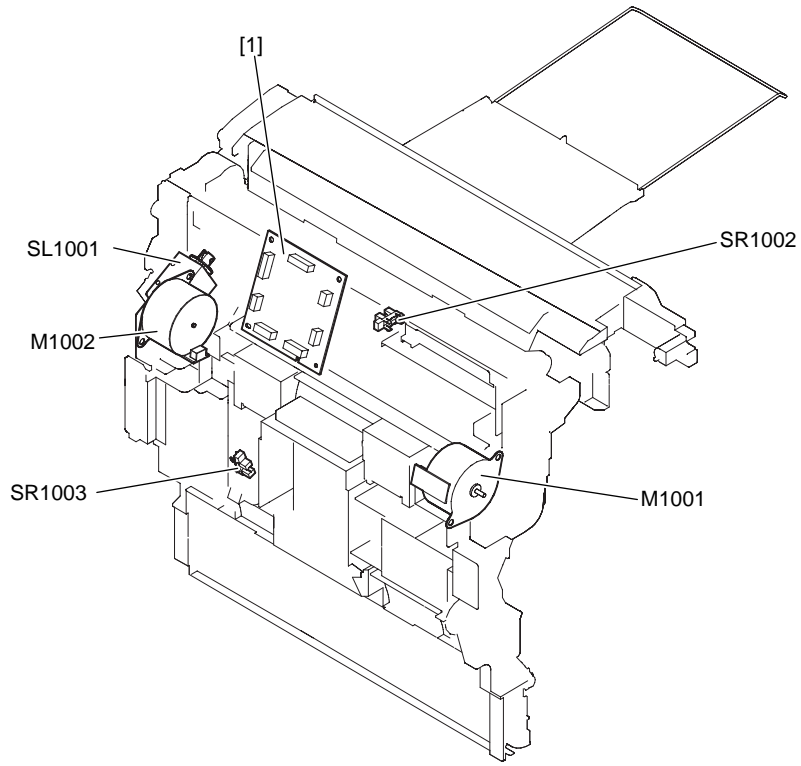

F-3-1  
T-3-1

Ref.	Name	Parts number	JAM code/E code
[1]	Duplex controller PCB	FM2-4515	E052
M1001	Feed motor	FK2-1114	
M1002	Reversal motor	FK2-1114	
SL1001	Duplex flapper solenoid	FL2-3744	
SR1002	Duplex paper sensor 1 (upper)	WG8-5696	0120, 0221
SR1003	Duplex paper sensor 2 (lower)	WG8-5696	0124, 0228



# Chapter 4 System Construction

## 4.1 Basic Construction

### 4.1.1 Outline

The operation sequence of the duplex unit is controlled by the duplex controller PCB. An 8-bit microcomputer mounted on the duplex controller PCB controls the operation sequence of the duplex unit and the serial communication with the DC controller PCB.

The duplex controller PCB drives motors in response to various commands sent from the DC controller PCB. The DC controller PCB sends the duplex unit status back to the printer. The duplex unit is powered by 24 VDC supplied from the power supply kit PCB and +5VDC and +3.3 VDC supplied from the DC controller PCB.

The duplex unit circuit configuration is shown below.

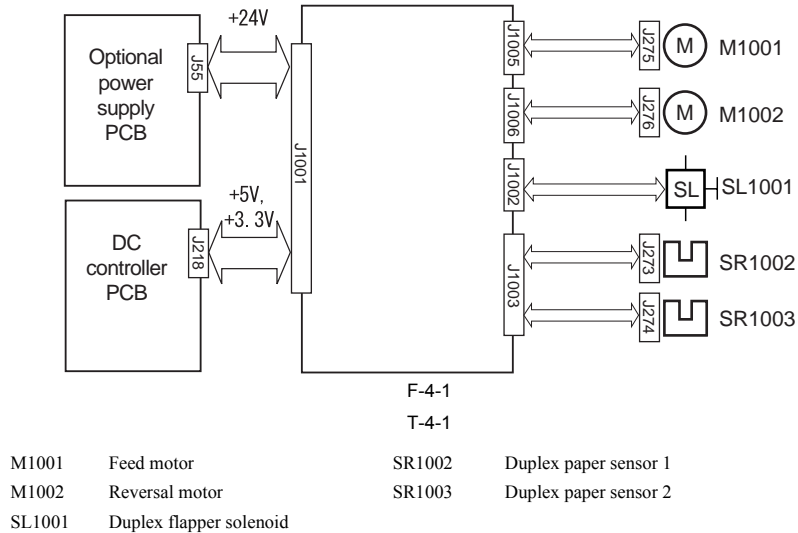

## 4.2 Product Specifications

### 4.2.1 Specifications

T-4-2

Item	Description	Remarks
Type	Built in the host machine	
Paper supply method	Switchback reversing method	
Copy paper type	60g/m2 to 90g/m2	
Copy paper size	A3, B4, A4, A4R, B5, B5R, A5R, 11X17, LGL, LTR, LTR-R, STMTR	
Power supply	DC power supply from host machine	
Weight	2.5 kg	
Dimensions	437.2 mm x 448 mm x 378.3 mm (W x D x H)	Incl. reversal tray dimensions





Sep 14 2005

